

Avelair

compressed air solutions

EDN / EDR 11kW to 15kW

49 cfm to 58 cfm • 6 to 15 bar pressure

Avelair Compressed Air Systems is the leading UK manufacturer of rotary screw air compressors. Our focus on quality workmanship and specialised components has ensured that the Avelair compressor is one of the most energy efficient and high performance rotary screw air compressors in the global market today.

Avelair have provided high quality turnkey compressed air solutions into a wide range of industries including workshops and garages, factories, water treatment sites and offshore.

Our service backup is second to none with full technical support and parts backup here in the UK 24 hours a day, 7 days a week.

Avelair have the ability to offer our systems as stand alone units or as multi-functional solutions to offer stored, dry and oil free compressed air. Whatever the requirement, we are able to offer a tailored solution suitable for each application.



EDI Series



Built in the UK

Built in the UK ensuring high quality workmanship, spare parts and service kits are stocked ready for immediate dispatch. Technical advice and customer support is available, one phone call away.



High Efficiency Motors

High efficiency IE 2/3 motors ensure optimum energy efficiency and offers a tax relief incentive via the Government's Enhanced Capital Allowance Scheme.



Optimum Control

The Avelair compressor is fitted with our optimum, user friendly control system which automatically monitors the compressor.



Long Term Reliability

The Avelair compressors are built in the UK using quality components and solid piping to ensure long term reliability.



Ease of Maintenance

Layout of components enables reduced servicing costs. Since the compressors can be completely serviced from the front, they can be positioned against a wall.

Compressor & Vehicle Lift Services

www.garageequipmentdirect.co.uk

Tel: 024 76491973



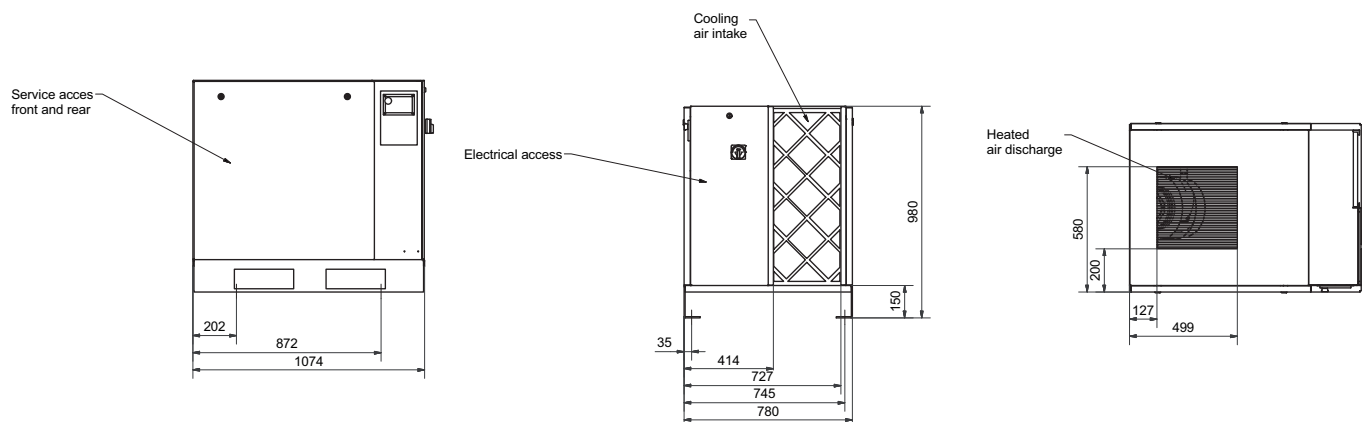

The Avelair Rotary Screw Air Compressor, Model type EDN, is a packaged, industrial rotary screw air compressor, pre-wired and tested, ready for commissioning.

Compressor

High efficiency intake air filter. Normally closed intake valve. Two stage oil separation system with scavenge sight glass. Integral air end and sump/separator which requires no separate certification or testing. Spin on, spin off air/oil separator. Quick oil drain feature. Oil thermostatic valve. Oil filter. Rigid steel tube fitted with olive and nuts. Combined air blast, high efficiency air/oil cooler. Separate motor driven cooling fan.

Drive

Electric drive motor with optimum specification belt drive power transmission. One shot, long life belt tensioning.

Instrumentation

Pressure control switch with variable time unload and shut-down control. High temperature shut-down switch. Line pressure gauge. Electronic display with start/stop and emergency stop button.

Enclosure

Non pressurised, high quality finish steel enclosure, fitted with flame retardent silencing foam. Full access, doors with lift-off facility, fitted with special manual locks, and intake dust pre-filter. **Full service accessibility from front of machine.**

MODEL	EDN 11	EDN 15	GENERAL DATA	
Motor	11 kW	15 kW	Motor enclosure	IP55
Capacity 8 bar	58 cfm	72 cfm	Motor Insulation / temp rise	Class F / B
Capacity 10 bar	49 cfm	56 cfm	Electrical enclosure	IP54
Capacity 13 bar	38 cfm	46 cfm	Control circuit	24 volt
Full load current	21 amps	26 amps	Max / min ambient temperature	45°C / >1°C
Isolator rating	30 amps	60 amps	Required cooling air flow	2,500 m ³ /hr
MCB (motor rated)	32 amps	40 amps	Oil carry over	2/3 ppm
Cable size (6 mtr)	6 mm ²	6 mm ²	Noise level at 1 metre	74 dB(A)
Starter	Star Delta	Star Delta	Weight	350 kg
Height*	980 mm	980 mm	Max / min pressure switch d/p	2.5 / 0.7 bar
Length*	1,074 mm	1,074 mm	Outlet connection size	½" / ¾" bspm
Width*	780 mm	780 mm	Oil capacity	5 litres

Specification subject to change without notice *Measurements include such items as isolator, emergency stop button etc

Compressor & Vehicle Lift Services

www.garageequipmentdirect.co.uk Tel: 024 76491973

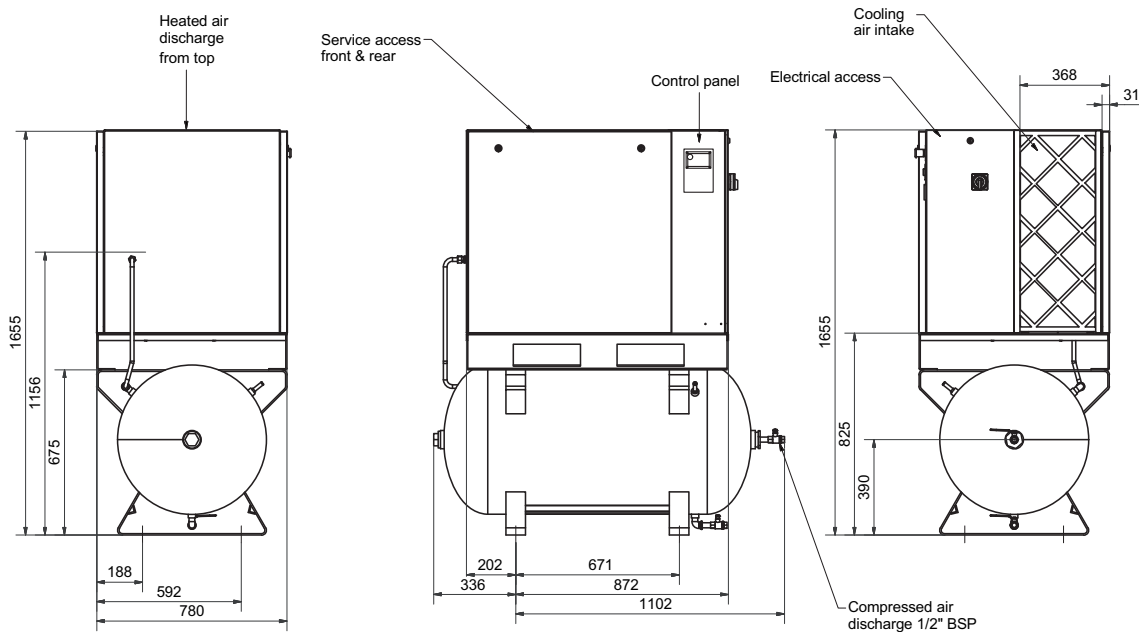

The Avelair Rotary Screw Air Compressor, Model type EDR, is a packaged, industrial rotary screw air compressor, mounted on a 300 litre horizontal air receiver to EN286-1:1991 Class 2, pre-wired and tested, ready commissioning.

Compressor

High efficiency intake air filter. Normally closed intake valve. Two stage oil separation system with scavenge sight glass. Integral air end and sump/separator which requires no separate certification or testing. Spin on, spin off air/oil separator. Quick oil drain feature. Oil thermovalve. Oil filter. Rigid steel tube fitted with olive and nuts. Combined air blast, high efficiency air/oil cooler. Separate motor driven cooling fan.

Drive

Electric drive motor with optimum specification belt drive power transmission. One shot, long life belt tensioning.

Instrumentation

Pressure control switch with variable time unload and shut-down control. High temperature shut-down switch. Line pressure gauge. Electronic display with start/stop and emergency stop button.

Enclosure

Non pressurised, high quality finish steel enclosure, fitted with flame retardent silencing foam. Full access, doors with lift-off facility, fitted with special manual locks, and intake dust pre-filter. **Full service accessibility from front of machine.**

MODEL	EDR 11	EDR 15	GENERAL DATA	
Motor	11 kW	15 kW	Motor enclosure	IP55
Capacity 8 bar	58 cfm	72 cfm	Motor Insulation / temp rise	Class F / B
Capacity 10 bar	49 cfm	56 cfm	Electrical enclosure	IP54
Capacity 13 bar	38 cfm	46 cfm	Control circuit	24 volt
Full load current	21 amps	27 amps	Max / min ambient temperature	45°C / >1°C
Isolator rating	30 amps	60 amps	Required cooling air flow	2,500 m ³ /hr
MCB (motor rated)	32 amps	40 amps	Oil carry over	2/3 ppm
Cable size (6 mtr)	6 mm ²	6 mm ²	Noise level at 1 metre	74 dB(A)
Starter	Star Delta	Star Delta	Weight	495 kg
Height*	1,655 mm	1,655 mm	Max / min pressure switch d/p	2.5 / 0.7 bar
Length*	1,438 mm	1,438 mm	Outlet connection size	½" / ¾" bspm
Width*	780 mm	780 mm	Oil capacity	5 litres

Specification subject to change without notice *Measurements include such items as isolator, emergency stop button etc

Compressor & Vehicle Lift Services

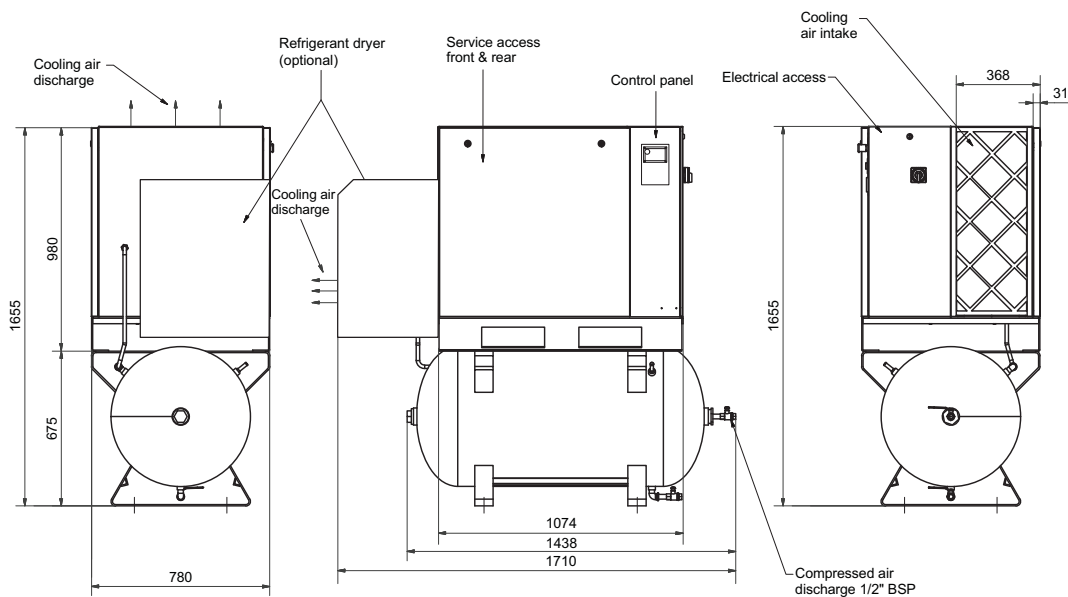

The Avelair Rotary Screw Air Compressor is a packaged, industrial rotary screw air compressor, mounted on a 300 litre horizontal air receiver to EN286-1:1991 Class 2, pre-wired and tested, ready commissioning. The Avelair range is available with the option of an integrated refrigerant dryer and filtration for oil-free, dry air.

Compressor

High efficiency intake air filter. Normally closed intake valve. Two stage oil separation system with scavenge sight glass. Integral air end and sump/separator which requires no separate certification or testing. Spin on, spin off air/oil separator. Quick oil drain feature. Oil thermovalve. Oil filter. Rigid steel tube fitted with olive and nuts. Combined air blast, high efficiency air/oil cooler. Separate motor driven cooling fan.

Drive

Electric drive motor with optimum specification belt drive power transmission. One shot, long life belt tensioning.

Instrumentation

Pressure control switch with variable time unload and shut-down control. High temperature shut-down switch. Line pressure gauge. Electronic display with start/stop and emergency stop button. Dewpoint indicator and on/off button available with integrated refrigerant dryer option.

Enclosure

Non pressurised, high quality finish steel enclosure, fitted with flame retardent silencing foam. Full access, doors with lift-off facility, fitted with special manual locks, and intake dust pre-filter. **Full service accessibility from front of machine.**

MODEL	EDR 11	EDR 15	GENERAL DATA	
Motor	11 kW	15 kW	Motor enclosure	IP55
Capacity 8 bar	58 cfm	72 cfm	Motor Insulation / temp rise	Class F / B
Capacity 10 bar	49 cfm	56 cfm	Electrical enclosure	IP54
Capacity 13 bar	38 cfm	46 cfm	Control circuit	24 volt
Full load current	23 amps	29 amps	Max / min ambient temperature	45°C / >1°C
Isolator rating	30 amps	60 amps	Required cooling air flow	2,500 m ³ /hr
MCB (motor rated)	32 amps	40 amps	Oil carry over	2/3 ppm
Cable size (6 mtr)	6 mm ²	6 mm ²	Noise level at 1 metre	74 dB(A)
Starter	Star Delta	Star Delta	Weight (without dryer option)	495 kg
Height*	1,655 mm	1,655 mm	Max / min pressure switch d/p	2.5 / 0.7 bar
Length* (without dryer option)	1,438 mm	1,438 mm	Outlet connection size	½" / ¾" bspm
Width*	780 mm	780 mm	Oil capacity	5 litres

Specification subject to change without notice *Measurements include such items as isolator, emergency stop button etc